

ENA Series

Side-Mounting Shaft Type Incremental Rotary Encoder

■ Features

- Strong die cast structure against external impact
- Convenient structure for direct mounting on the frame
- Connector type
- Power supply: 5VDC, 12-24VDC ±5%

⚠ Please read "Safety Considerations" in the instruction manual before using.



■ Ordering Information

ENA	5000	3	N	24
Series	Pulses/revolution	Output phase	Control output	Power supply
Side-mounting shaft type (external diameter of shaft: Ø10mm)	Refer to resolution	2: A, B 3: A, B, Z	T: Totem pole output N: NPN open collector output V: Voltage output	5 : 5VDC ±5% 24: 12-24VDC ±5%

■ Specifications

Item	Side-mounting Shaft Type Incremental Rotary Encoder		
Resolution (PPR) ^{※1}	*1, *2, *5, 10, 12, 15, 20, 23, 25, 30, 35, 40, 45, 50, 60, 75, 100, 120, 150, 192, 200, 240, 250, 256, 300, 360, 400, 500, 512, 600, 800, 1000, 1024, 1200, 1500, 1800, 2000, 2048, 2500, 3000, 3600, 5000		
Electrical specification	Output phase	•ENA-□-2-□-□: A, B phase •ENA-□-3-□-□: A, B, Z phase	
	Phase difference of output	Phase difference between A and B: $\frac{T}{4} \pm \frac{T}{8}$ (T=1 cycle of A phase)	
	Control output	Totem pole output	• [Low] - Load current: max. 30mA, residual voltage: max. 0.4VDC≒ • [High] - Load current: max. 10mA, output voltage (power voltage 5VDC≒): min. (power voltage-2.0)VDC≒, output voltage (power voltage 12-24VDC≒): min. (power voltage-3.0)VDC≒
		NPN open collector output	Load current: max. 30mA, residual voltage: max. 0.4VDC≒
		Voltage output	Load current: max. 10mA, residual voltage: max. 0.4VDC≒
	Response time (rise/fall)	Totem pole output	Max. 1μs (cable length: 2m, I sink = 20mA)
		NPN open collector output	
		Voltage output	
	Max. response frequency	300kHz	
	Power supply	• 5VDC≒ ±5% (ripple P-P: max. 5%) • 12-24VDC≒ ±5% (ripple P-P: max. 5%)	
Current consumption	Max. 80mA (disconnection of the load)		
Insulation resistance	Over 100MΩ (at 500VDC megger between all terminals and case)		
Dielectric strength	750VAC 50/60Hz for 1 minute (between all terminals and case)		
Connection	Radial connector type		
Mechanical specification	Starting torque	Max. 70gf·cm (0.007N·m)	
	Moment of inertia	Max. 80g·cm ² (8×10 ⁻⁶ kg·m ²)	
	Shaft loading	Radial: max. 10kgf, Thrust: max. 2.5kgf	
	Max. allowable revolution ^{※2}	5,000rpm	
Vibration	1.5mm amplitude at frequency of 10 to 55Hz (for 1 min) in each X, Y, Z direction for 2 hours		
Shock	Approx. max. 75G		
Environment	Ambient temperature	-10 to 70°C, storage: -25 to 85°C	
	Ambient humidity	35 to 85%RH, storage: 35 to 90%RH	
Protection structure	IP50 (IEC standard)		
Cable	ENA-□-2-□-□	Ø5mm, 4-wire, 2m, Shield cable (AWG 24, core diameter: 0.08mm, number of cores: 40, insulator out diameter: Ø1mm)	
	ENA-□-3-□-□	Ø5mm, 5-wire, 2m, Shield cable (AWG 24, core diameter: 0.08mm, number of cores: 40, insulator out diameter: Ø1mm)	
Accessory	Ø10mm coupling, Connector cable		
Approval	CE		
Unit weight	Approx. 345g		

※1: '*' pulse is only for A, B phase. Not indicated resolutions are customizable.

※2: Make sure that max. response revolution should be lower than or equal to max. allowable revolution when selecting the resolution.

$$[\text{Max. response revolution (rpm)}] = \frac{\text{Max. response frequency}}{\text{Resolution}} \times 60 \text{ sec}$$

※Environment resistance is rated at no freezing or condensation.

Incremental Side-Mounting Shaft Type

Control Output Diagram

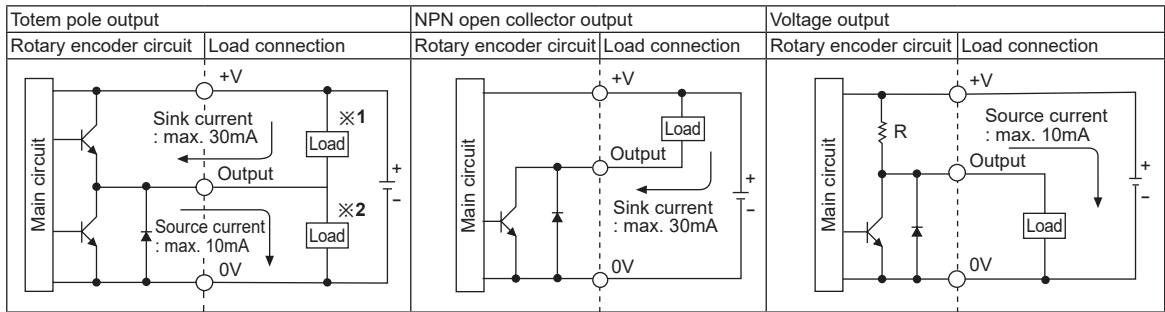

- The output circuits of A, B, Z phase are same.
- Totem pole output type can be used for NPN open collector type (※1) or voltage output type (※2).

Output Waveform

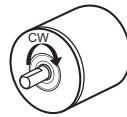
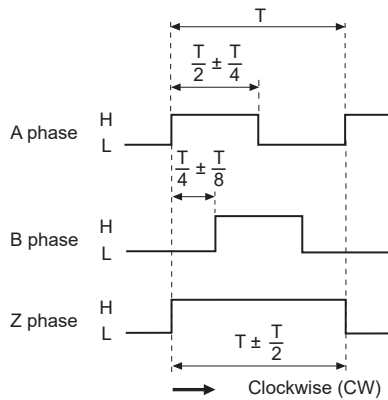

※In case of ENA-□-3-□-□ model, Z phase is output.

Connections

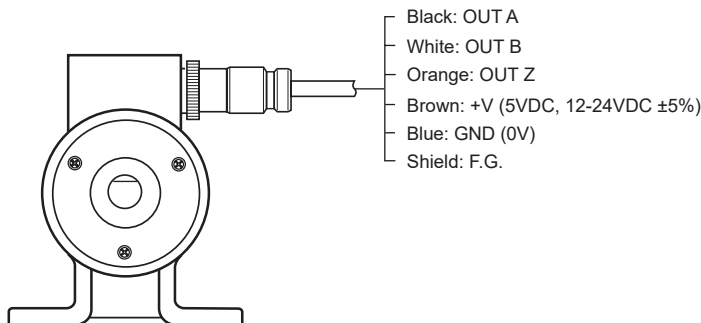

Pin No	Cable color	Function
①	Black	OUT A
②	White	OUT B
③	Brown	+V
④	Blue	GND
⑤	Blue	GND

- ※In case of ENA-□-3-□-□ model, Z phase is output.
- ※Unused wires must be insulated.
- ※The metal case and shield cable of encoder must be grounded (F.G.).
- ※Do not apply tensile strength over 30N to the cable.

SENSORS

CONTROLLERS

MOTION DEVICES

SOFTWARE

(A) Photoelectric Sensors

(B) Fiber Optic Sensors

(C) LIDAR

(D) Door/Area Sensors

(E) Vision Sensors

(F) Proximity Sensors

(G) Pressure Sensors

(H) Rotary Encoders

(I) Connectors/ Connector Cables/ Sensor Distribution Boxes/ Sockets

ENA Series

■ Dimensions

(unit: mm)

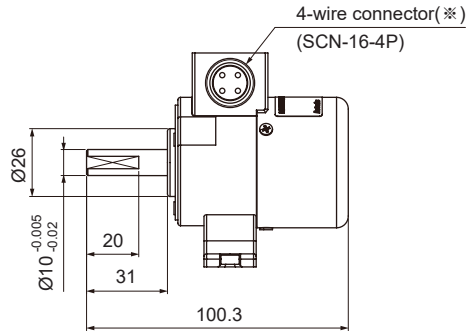
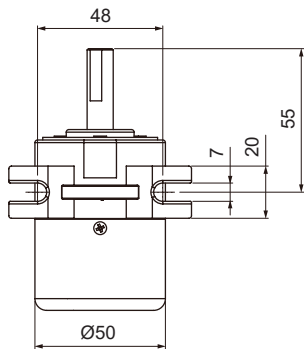
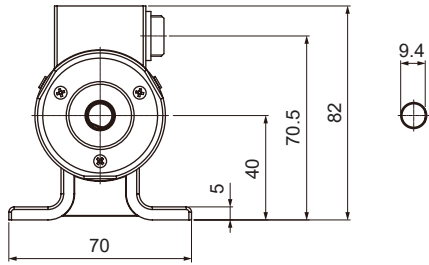

※ ENA-□-3-□-□
: 5-wire connector
(SCN-16-5P)

◎ Connector cable

• ENA-□-2-□ (2m, 4-wire)

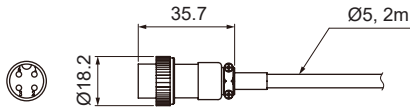

• ENA-□-3-□ (2m, 5-wire)

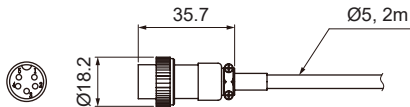

◎ Coupling

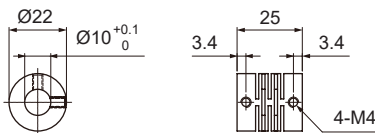

- Parallel misalignment: max. 0.25mm
- Angular misalignment: max. 5°
- End-play: max. 0.5mm

※ Do not load overweight on the shaft.

※ Do not put strong impact when insert a coupling into shaft. Failure to follow this instruction may result in product damage.

※ Fix the unit or a coupling by a wrench under 0.15N·m of torque.

※ When you install this unit, if eccentricity and deflection angle are larger, it may shorten the life cycle of this unit.

※ For parallel misalignment, angular misalignment, end-play terms, refer to the "Glossary" section of Technical Description.

※ For flexible coupling (ERB series) information, refer to the ERB series section.